

### Table for standard stroke

	Tube I.D.	Stroke (mm)
Single acting	ø16	15,25,50,75,100
	ø20,25	15,25,50,75,100,125,150
Double acting	ø8,10	10,25,40,50,80,100
	ø12	10,25,40,50,80,100,125,160,200
	ø16,20,25 ø32,40	15,25,50,75,100,125,150,200,250, 300,350,400,450,500

\* Stroke out of specification is also available.

\* Please consult us if stroke out of specification.

### Features

#### ■ Non lubrication

Special housing and bushing enables self lubrication of piston rod.

#### ■ High quality long service life

Hard anodised stainless steel cylinder tubes offer a high resistance to corrosion and low internal friction.

#### ■ Cylinder mountings

Available with a comprehensive range of accessories for rigid or flexible mounting.

#### ■ ISO-6432 standard (ø8~ø25)

Enables world-wide inter-changeability.

#### ■ Port thread Rc. NPT. are also available

#### ■ Magnetic as standard

### Specification

Model		MCMI							
Tube I.D. (mm)		8	10	12	16	20	25	32	40
Port size		M5×0.8				G1/8		G1/4	
Medium		Air							
Max. operating pressure		0.7 MPa							
Min. operating pressure (MPa)	Double acting	0.1	0.08		0.06				
	Single acting	Extended	—		0.23		—		
		Returned	—		0.18		—		
Proof pressure		1 MPa							
Lubricator		Not required							
Ambient temperature		-5~+60°C (No freezing)							
Available speed range		50~500 mm/sec							
Max. allowable kinetic energy (J)	Cushion pad	0.02	0.03	0.04	0.09	0.27	0.4	0.65	1.2
	Cushion air	—	—	—	0.4	0.66	0.97	1.27	2.35
Sensor switch (*)		RCM (Please refer to page 8-15)							
Sensor switch (band)		BM8	BM10	BM12	BM16	BM20	BM25	BM32	BM40

\* For precautions, please refer to page 3-2.

### Tightening torque

Tube I.D.	Rod thread	Tightening torque (kgf·cm)
ø8	M4×0.7	11.8
ø10	M4×0.7	11.8
ø12	M6×1.0	41
ø16	M6×1.0	41
ø20	M8×1.25	170
ø25	M10×1.25	340
ø32	M10×1.25	340
ø40	M12×1.25	590

\* Make sure the tightening torque of rod thread does not exceed the value above. The tolerance of tightening torque is ±5%.

### Order example

**MCFI — 11 — 16 — 100 — A — NC**

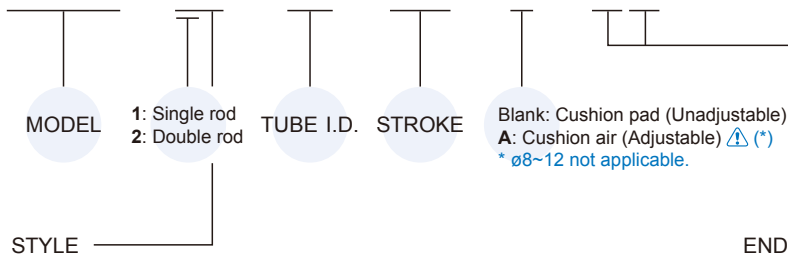

Code	Symbol	Description	Tube I.D.
1 1		Double acting / Male thread	$\phi 8\sim\phi 40$
1 3		Single acting / Normally extended male thread	$\phi 16\sim\phi 25$
1 5		Single acting / Normally returned male thread	
2 1		Double rod / Male thread	
2 7		Double rod / Adjustable male thread Please mark "adjustable distance(mm)" at order list	

\* Single acting type, please consult us.  
 \* Order example for special specification, refer to page 0-7.

### END COVER TYPE

Code	Symbol	Description	Tube I.D.
-		Standard type	$\phi 8\sim\phi 25$
N		Non-pivot type	
R		Rod clevis	$\phi 32\sim\phi 40$
H		Head clevis	
F		Head foot type	

\* (R), (H) not suitable for (A) cushion air.

### PORT POSITION

Code	Symbol	Description	Tube I.D.	Suitable end cover
-		Standard type	$\phi 8\sim\phi 40$	All end cover
C		Axial port	$\phi 32\sim\phi 40$	N, R

### Mounting accessories

**LB — MCFI — 16**

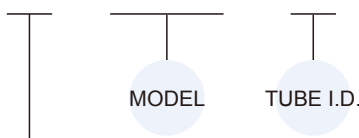

### MOUNTING TYPE

	LB	Only for $\phi 8\sim\phi 25$
	FA	
	FB	
	SDB	
	Y	
	I	
	YS (Y+Floating pin)	

\* Y, I, YS, please refer to page 3-14.

### Caution

For (A) Cushion air (Adjustable)

- To adjust a cushion needle, please slowly turn the needle valve from the fully closed status to the required status whose turns need to be within 2.5 circles.
- If the needle valve loosen excessively, the buffer can't take effect and the lifetime of cylinder can shorten.

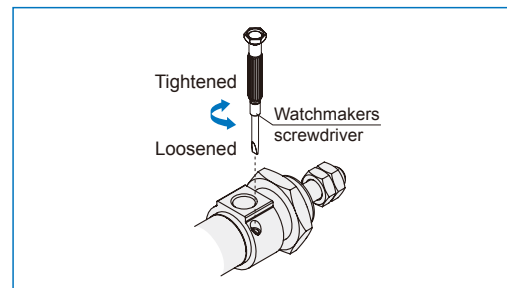

ø8, ø12

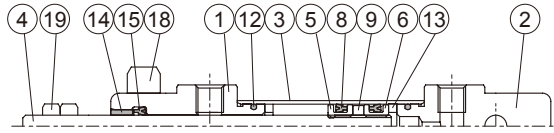

ø10

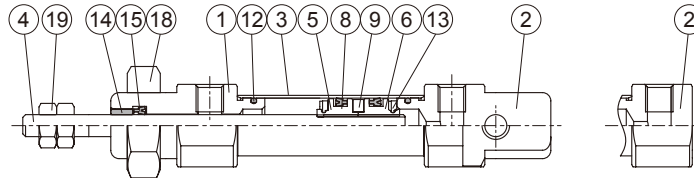

N type: ø8~ø40

ø16~ø25

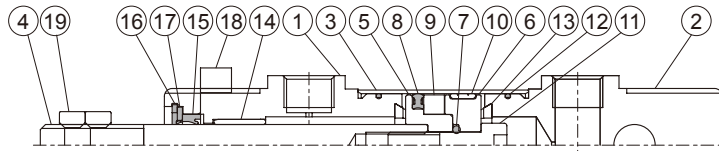

15 type: ø16

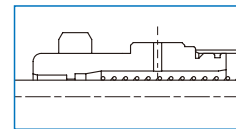

ø32, ø40

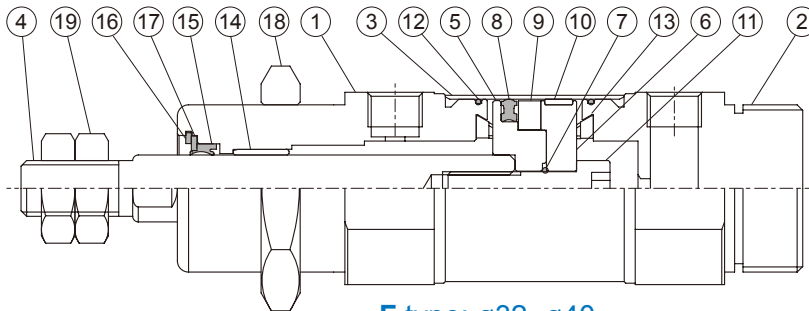

F type: ø32~ø40

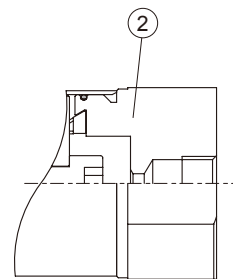

C type: ø32~ø40

### Material

\* Style 21 is not applicable in cylinder bore ø8~ø12.  
\* Repair kit is not applicable for cylinder bore ø8~ø12.

### Order example

#### Component parts / Repair kits

No.	Tube I.D. Part name	8	10	12	16	20	25	32	40	Q'y		Component parts (inclusion)		Repair kits (inclusion)
										11 type	21 type	11 type	21 type	
1	Rod cover	Aluminum alloy								1	2	●	●	
2	Head cover	Aluminum alloy								1	—	●		
3	Tube	Stainless steel								1	1			
4	Piston rod	Stainless steel				Carbon steel				1	1			
5	Piston-R	Aluminum alloy								1	1	●	●	
6	Piston-H	Aluminum alloy								1	1	●	●	
7	Piston gasket	—		NBR						1	1	●	●	
8	Piston packing	NBR								1*1	1*1	●	●	
9	Magnet ring	Magnet material								1	1	●	●	
10	Wear ring	—		POM						1	1	●	●	
11	Piston bolt	—		SCM						1	—	●		
12	Cover ring	NBR								2	2	●	●	
13	Cushion gasket	NBR								2	2	●	●	
14	Rod bush	Bearing alloy								1	2	●	●	
15	Rod packing	NBR								1	2	●	●	●
16	Snap ring	—		Spring steel						1	2	●	●	
17	Washer	—		Carbon steel						1	2	●	●	
18	Tie nut	Carbon steel								1	2	●	●	
19	Rod front nut	Carbon steel								2	2	●	●	

Tube I.D.	Component parts	Repair kits
ø8	CP-MCFI-8	PS-MCFI-8
ø10	CP-MCFI-10	PS-MCFI-10
ø12	CP-MCFI-12	PS-MCFI-12
ø16	CP-MCFI-16	PS-MCFI-16
ø20	CP-MCFI-20	PS-MCFI-20
ø25	CP-MCFI-25	PS-MCFI-25
ø32	—	PS-MCFI-32
ø40	—	PS-MCFI-40

### End cover type

Tube I.D.	Component parts	N	R	H	F
ø8	CP-MCFI-8	-N			
ø10	CP-MCFI-10	-N			
ø12	CP-MCFI-12	-N			
ø16	CP-MCFI-16	-N			
ø20	CP-MCFI-20	-N			
ø25	CP-MCFI-25	-N			
ø32	CP-MCFI-32	-N	-R	-H	-F
ø40	CP-MCFI-40	-N	-R	-H	-F

\*1. ø8~ø12 (Q'y: 2 psc)

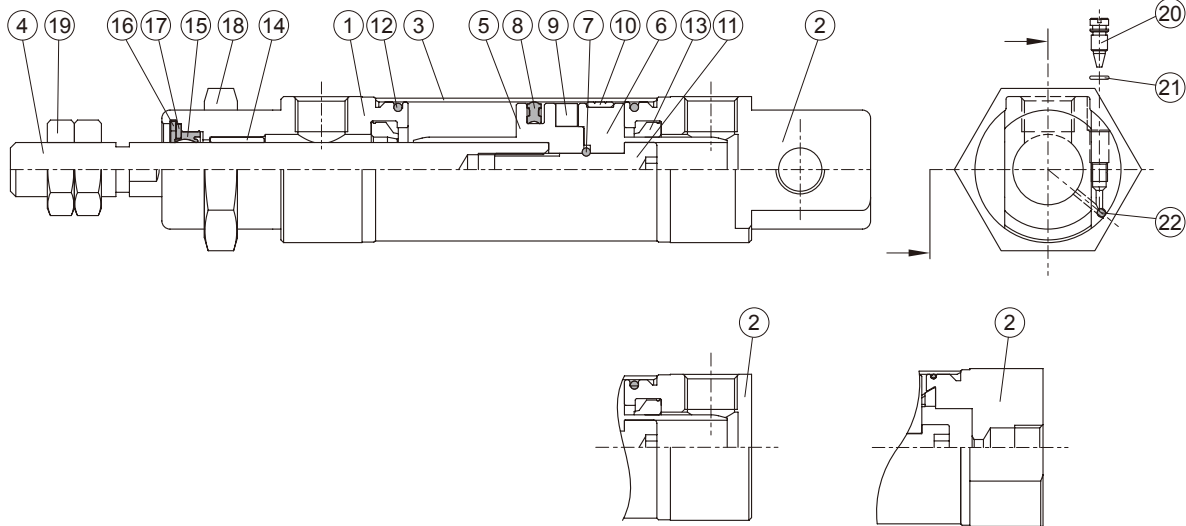

N type: ø16~ø40

C type: ø32~ø40

### Material \* Cylinder bore ø8~12 is not applicable.

No.	Tube I.D. Part name	16	20	25	32	40	Q'y		Component parts (inclusion)		Repair kits (inclusion)
							11 type	21 type	11 type	21 type	
1	Rod cover	Aluminum alloy					1	2	●	●	
2	Head cover	Aluminum alloy					1	—	●		
3	Tube	Stainless steel					1	1			
4	Piston rod	*1	Carbon steel					1	1		
5	Piston-R	Aluminum alloy					1	1	●	●	
6	Piston-H	Aluminum alloy					1	1	●	●	
7	Piston gasket	NBR					1	1	●	●	
8	Piston packing	NBR					1*2	1*2	●	●	
9	Magnet ring	Magnet material					1	1	●	●	
10	Wear ring	POM					1	1	●	●	
11	Piston bolt	SCM					1	—	●		
12	Cover ring	NBR					2	2	●	●	
13	Cushion packing	NBR					2	2	●	●	
14	Rod bush	Bearing alloy					1	2	●	●	
15	Rod packing	NBR					1	2	●	●	●
16	Snap ring	Spring steel					1	2	●	●	
17	Washer	Carbon steel					1	2	●	●	
18	Tie nut	Carbon steel					1	2	●	●	
19	Rod front nut	Carbon steel					2	2	●	●	
20	Needle valve	Stainless steel					2	2	●	●	
21	Needle valve packing	NBR					2	2	●	●	●
22	Steel ball	Stainless steel					2	2	●	●	

\*1. Stainless steel

\*2. ø8~ø12 (Q'y: 2 psc)

### Order example

#### Component parts / Repair kits

Tube I.D.	Component parts	Repair kits
ø16	CP-MCFI-16A	PS-MCFI-16A
ø20	CP-MCFI-20A	PS-MCFI-20A
ø25	CP-MCFI-25A	PS-MCFI-25A
ø32	—	PS-MCFI-32A
ø40	—	PS-MCFI-40A

#### End cover type

Tube I.D.	Component parts	N	R	H	F
ø16	CP-MCFI-16A	-N			
ø20	CP-MCFI-20A	-N			
ø25	CP-MCFI-25A	-N			
ø32	CP-MCFI-32A	-N	-R	-H	-F
ø40	CP-MCFI-40A	-N	-R	-H	-F

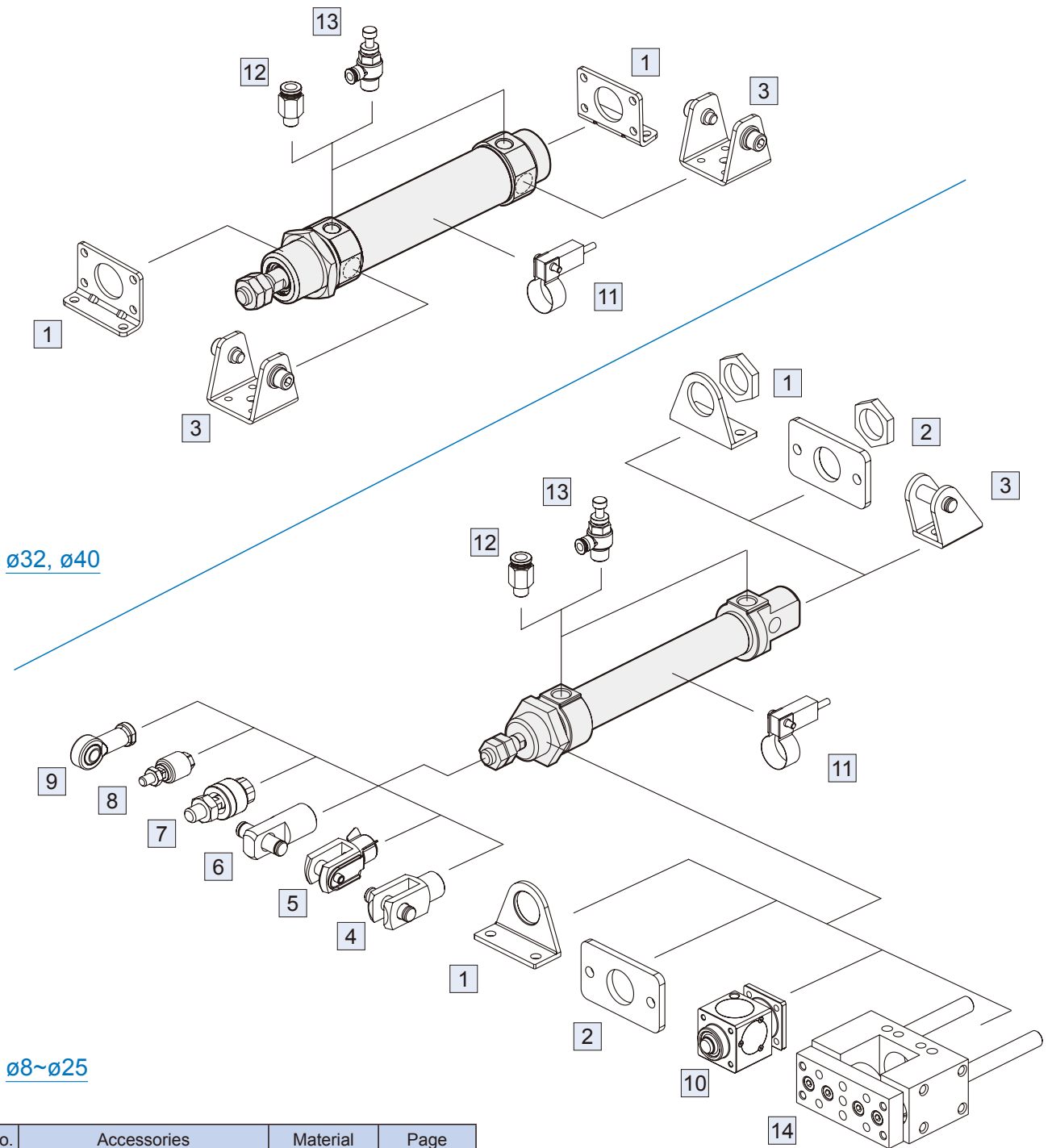

ø32, ø40

ø8~ø25

No.	Accessories	Material	Page
1	Mounting accessories LB	Carbon steel	3-49, 51
2	Mounting accessories FA/FB	Carbon steel	3-48, 49
3	Mounting accessories SDB+PIN	Carbon steel	3-48, 51, 14
4	Accessories Y+PIN	Carbon steel	3-14
5	Accessories YS (Y+Floating pin)	Carbon steel	3-14
6	Accessories I+PIN	Carbon steel	3-14
7	Floating joint MFC	Carbon steel	8-2
8	Floating joint MFCS	Carbon steel	8-5

\* Aluminum alloy + copper alloy

No.	Accessories	Material	Page
9	Female rod ends PHS	Carbon steel	8-6
10	Locking unit MCBMI	(*)	1-77
11	Sensor switch RCM+BM**	-	8-15
12	Fitting PC	-	7-3 (Vol.1)
13	Fitting JSC	-	7-15 (Vol.1)
14	Twin-guide cylinders MGTB/TK/TU	-	4-33

### ■ Installation of sensor switch

Sensor switch: RCM  
Sensor switch band: BM\*\*

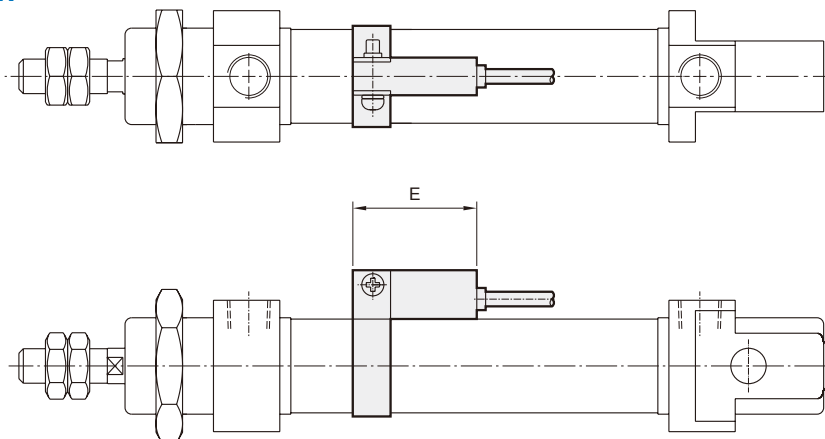
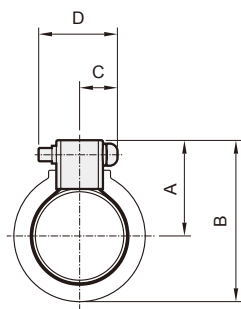

Code Tube I.D.	A	B	C	D	E
8	16	23.5	10	16	28
10	17	24.5	10	16	28
12	18	28	10	16	28
16	20	30	10	16	28
20	22	35.5	10	16	28
25	25	38.5	10	16	28
32	28	45.5	10	16	28
40	32	54	10	16	28

### ■ Cylinder & accessories weight

#### Cylinder weight

Unit: g

Model	Basic weight MCFI-11	Basic weight MCFI-11-A	Stroke 25 mm MCFI-11	Basic weight MCFI-11-N	Basic weight MCFI-11-A-N	Stroke 25 mm MCFI-11-*
Tube I.D.						
$\varnothing 8$	36	—	6	32	—	6
$\varnothing 10$	38	—	8	35	—	8
$\varnothing 12$	78	—	11	69	—	11
$\varnothing 16$	95	93	13	88	85	13
$\varnothing 20$	162	190	18	151	179	18
$\varnothing 25$	206	229	28	191	214	28

Model	Basic weight MCFI-11-F	Basic weight MCFI-11-A-F	Stroke 25 mm MCFI-11-F	Basic weight MCFI-11-N/C/R/H	Basic weight MCFI-11-A-N/C	Stroke 25 mm MCFI-11-*
Tube I.D.						
$\varnothing 32$	334	402	39	307	375	39
$\varnothing 40$	591	601	60	639	649	60

#### Accessories weight

Unit: g

Model	LB	FA/FB	SDB	Y	I	Pin	Rod nut	Cover nut
Tube I.D.								
$\varnothing 8$	42	16	16	4	—	2	1	8
$\varnothing 10$	42	16	16	4	—	2	1	8
$\varnothing 12$	65	25	24	13	15	4	2	16
$\varnothing 16$	65	25	24	13	15	5	2	11
$\varnothing 20$	103	67	103	40	42	10	4	20
$\varnothing 25$	103	67	103	72	82	19	8	20
$\varnothing 32$	160	—	111	—	—	—	8	28
$\varnothing 40$	246	—	164	—	—	—	10	41

11

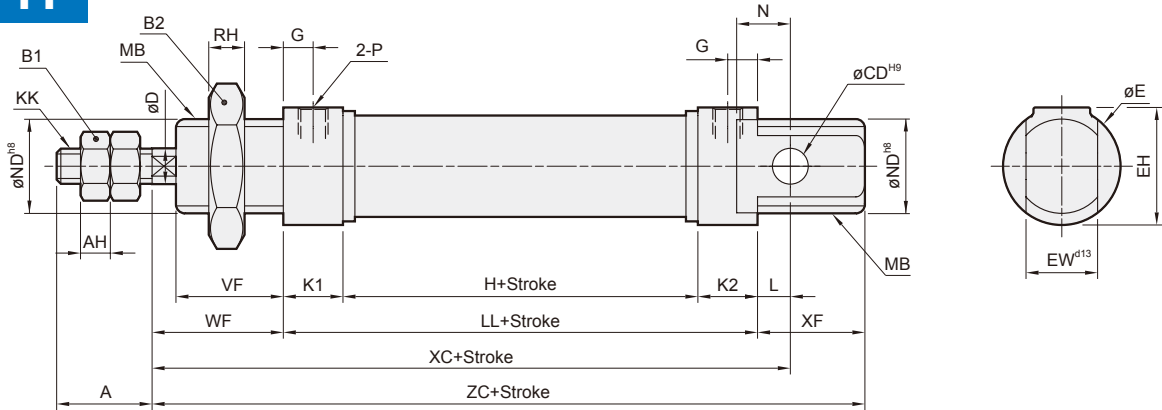

21

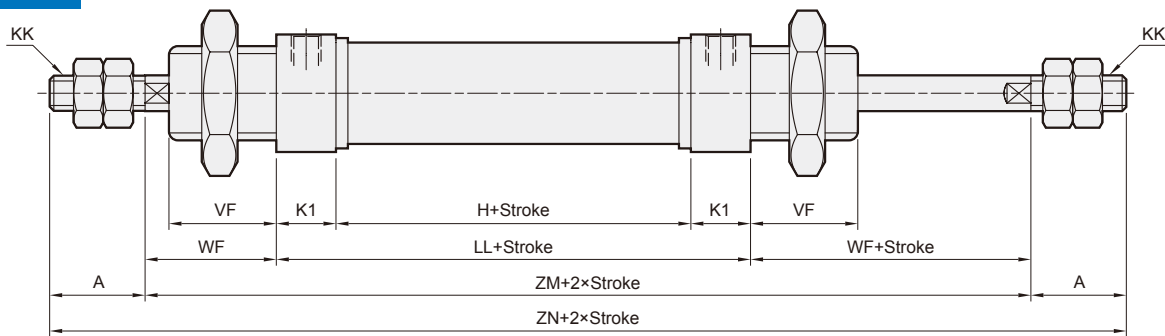

27

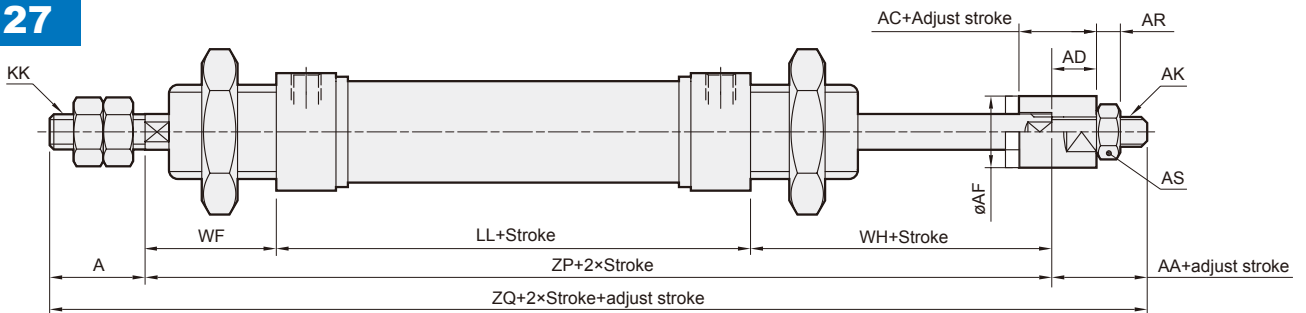

Code Tube I.D.	A	AA	AC	AD	AF	AH	AK	AR	AS	B1	B2	CD	D	E	EH	EW	G	H	KK	K1	K2	L	LL
8	12	—	—	—	—	3.2	—	—	—	7	19	4	4	15	15	8	6	24	M4×0.7	11	11	2	46
10	12	—	—	—	—	3.2	—	—	—	7	19	4	4	15	15	8	6	24	M4×0.7	11	11	2	46
12	16	—	—	—	—	5	—	—	—	10	24	6	6	20	20	12	6	28	M6×1.0	11	11	3	50
16	16	16	13	7.5	12	5	M5×0.8	4	8	10	22	6	6	20	20	12	5	34.5	M6×1.0	10	10	5.5	54.5
20	20	19	15	9.5	16	5	M8×1.25	5	13	13	30	8	8	27	27	16	8	38	M8×1.25	15	15	3	68
25	22	19	15	9.5	16	6	M8×1.25	5	13	17	30	8	10	27	27	16	7.5	37	M10×1.25	15	15	9	67

Code Tube I.D.	MB	N	ND	P	RH	VF	WF	WH	XC	XF	ZC	ZM	ZN	ZP	ZQ
8	M12×1.25	6	12	M5×0.8	6	12	16	—	64	12	74	—	—	—	—
10	M12×1.25	6	12	M5×0.8	6	12	16	—	64	12	74	—	—	—	—
12	M16×1.5	9	16	M5×0.8	8	17	22	—	75	17	89	—	—	—	—
16	M16×1.5	9	16	M5×0.8	6	18	22	25.5	82	18	94.5	98.5	130.5	102	134
20	M22×1.5	12	22	G1/8	6	20	24	27	95	20	112	116	156	119	158
25	M22×1.5	12	22	G1/8	6	22	28	29.5	104	22	117	123	167	124.5	165.5

**N**

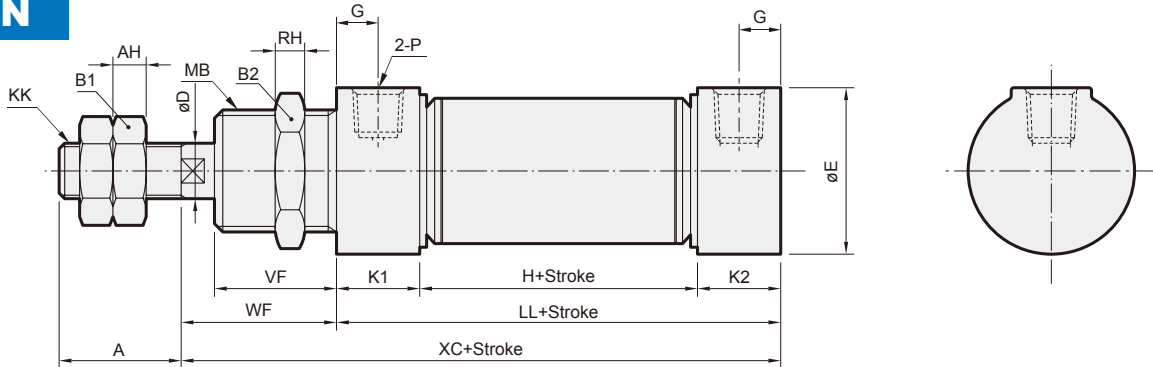

Code Tube I.D.	A	AH	B1	B2	D	E	G	H	KK	K1	K2	LL	MB	P	RH	VF	WF	XC
8	12	3.2	7	19	4	16.7	6	24	M4×0.7	11	11	46	M12×1.25	M5×0.8	6	12	16	62
10	12	3.2	7	19	4	16.7	6	24	M4×0.7	11	11	46	M12×1.25	M5×0.8	6	12	16	62
12	16	5	10	24	6	19.7	6	28	M6×1.0	11	11	50	M16×1.5	M5×0.8	8	17	22	72
16	16	5	10	22	6	20	5	34.5	M6×1.0	10	10	54.5	M16×1.5	M5×0.8	6	18	22	76.5
20	20	5	13	30	8	27	8	38	M8×1.25	15	15	68	M22×1.5	G1/8	6	20	24	92
25	22	6	17	30	10	27	7.5	37	M10×1.25	15	15	67	M22×1.5	G1/8	6	22	28	95

**13**

**15**

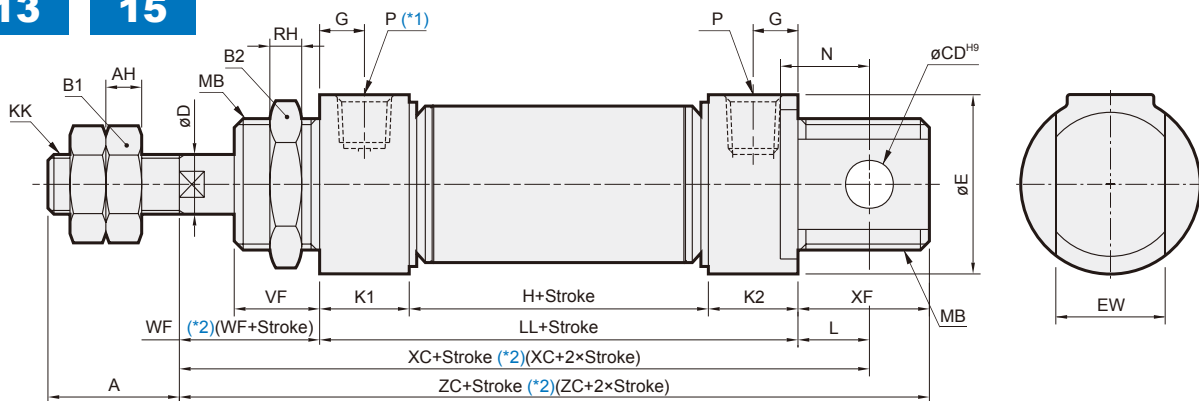

\*1. 15 type ø16 without this air port.

\*2. ( ) Dimension for 13 type.

Code Tube I.D.	A	AH	B1	B2	CD	D	E	EW	G	KK	K1	K2	L	LA	MB	N	P	RH	VF	WF	XF	ZM	ZN	ZP	ZQ
16	16	5	10	22	6	6	20	12 <sup>-0.05/-0.4</sup>	5	M6×1.0	10	10	5.5	54.5	M16×1.5	9	M5×0.8	6	18	22	18	98.5	130.5	96	134
20	20	5	13	30	8	8	27	16 <sup>-0.05/-0.4</sup>	8	M8×1.25	15	15	3	68	M22×1.5	12	G1/8	6	20	24	20	116	156	119	158
25	22	6	17	30	8	10	27	16 <sup>-0.05/-0.4</sup>	7.5	M10×1.25	15	15	9	67	M22×1.5	12	G1/8	6	22	28	22	123	167	124.5	165.5

**MCFM-13**

Code Stroke Tube I.D.	H			LL			XC			ZC		
	1~50	51~100	101~150	1~50	51~100	101~150	1~50	51~100	101~150	1~50	51~100	101~150
16	53.5	79.5	105.5	73.5	99.5	125.5	101	127	153	113.5	139.5	165.5
20	63	88	113	93	118	143	120	145	170	137	162	187
25	60.5	85.5	110.5	90.5	115.5	140.5	127.5	152.5	177.5	140.5	165.5	190.5

**MCFM-15**

Code Stroke Tube I.D.	H			LL			XC			ZC		
	1~50	51~100	101~150	1~50	51~100	101~150	1~50	51~100	101~150	1~50	51~100	101~150
16	34.5	50	65.5	54.5	70	85.5	82	97.5	113	94.5	110	125.5
20	38	88	113	68	118	143	95	145	170	112	162	187
25	37	85.5	110.5	67	115.5	140.5	104	152.5	177.5	117	165.5	190.5



**FA / FB**

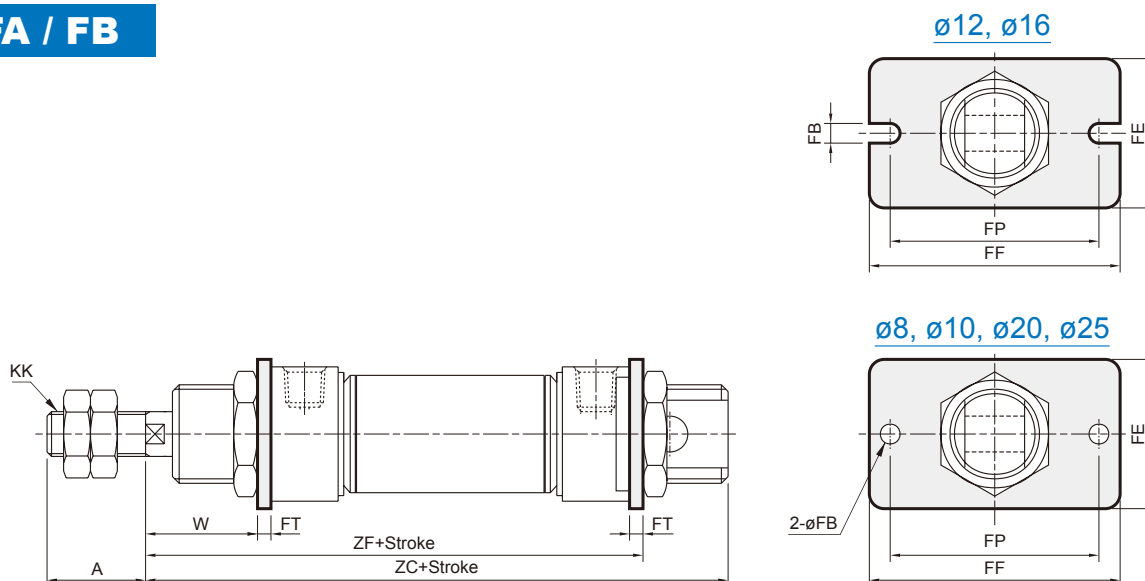

Code Tube I.D.	A	FB	FE	FF	FP	FT	KK	W	ZC	ZF
8	12	4.5	22	40	30	3.2	M4×0.7	12.8	74	65.2
10	12	4.5	22	40	30	3.2	M4×0.7	12.8	74	65.2
12	16	5.5	26	52	40	3.2	M6×1.0	18.8	89	75.2
16	16	5.5	26	52	40	3.2	M6×1.0	18.8	94.5	79.7
20	20	6.6	38	64	50	4.5	M8×1.25	19.5	112	96.5
25	22	6.6	38	64	50	4.5	M10×1.25	23.5	117	99.5

**SDB**

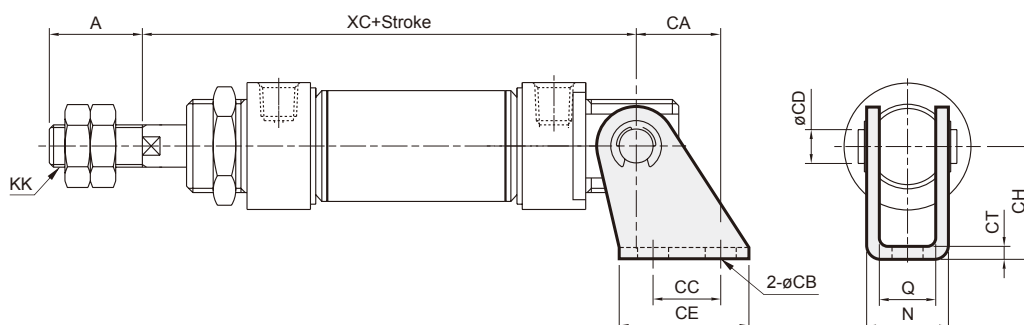

Code Tube I.D.	A	CA	CB	CC	CD	CE	CH	CT	KK	N	Q	XC
8	12	11	4.5	12.5	4	20	24	2.5	M4×0.7	13.1	8.1	64
10	12	11	4.5	12.5	4	20	24	2.5	M4×0.7	13.1	8.1	64
12	16	13	5.5	15	6	25	27	3.2	M6×1.0	18.5	12.1	75
16	16	13	5.5	15	6	25	27	3.2	M6×1.0	18.5	12.1	82
20	20	16	6.6	20	8	32	30	3.2	M8×1.25	22.5	16.1	95
25	22	16	6.6	20	8	32	30	3.2	M10×1.25	22.5	16.1	104

**LB**

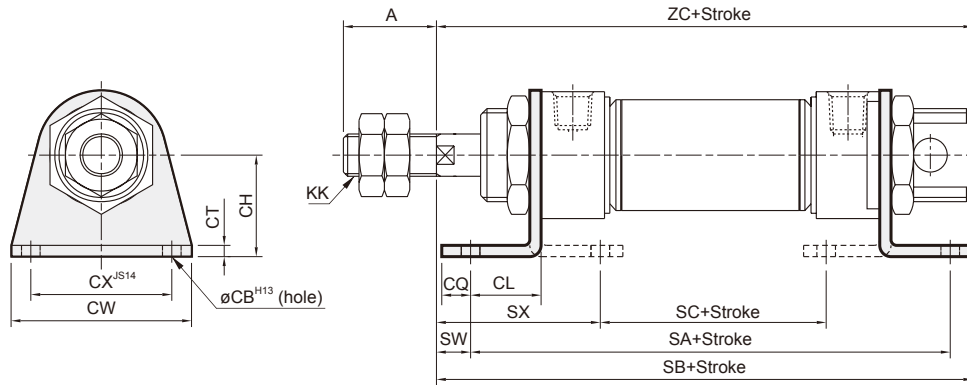

Code Tube I.D.	A	CB	CH	CL	CQ	CT	CW	CX	KK	SA	SB	SC	SW	SX	ZC
8	12	4.5	16	11	5	3.2	35	25	M4×0.7	68	78	30.4	5	23.8	74
10	12	4.5	16	11	5	3.2	35	25	M4×0.7	68	78	30.4	5	23.8	74
12	16	5.5	20	14	6	4	42	32	M6×1.0	78	92	30	8	32	89
16	16	5.5	20	14	6	4	42	32	M6×1.0	82.5	96.5	34.5	8	32	94.5
20	20	6.6	25	15	8	3.2	54	40	M8×1.25	98	115	44.4	9	35.8	112
25	22	6.6	25	15	8	3.2	54	40	M10×1.25	97	118	43.4	13	39.8	117

**FA**

**N**

Non-pivot type

Code Tube I.D.	A	FB	FE	FF	FP	FT	W	XC
8	12	4.5	22	40	30	3.2	12.8	62
10	12	4.5	22	40	30	3.2	12.8	62
12	16	5.5	26	52	40	3.2	18.8	72
16	16	5.5	26	52	40	3.2	18.8	76.5
20	20	6.6	38	64	50	4.5	19.5	92
25	22	6.6	38	64	50	4.5	23.5	96

ø12, ø16

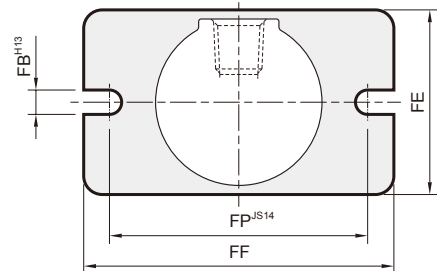

ø8, ø10, ø20, ø25

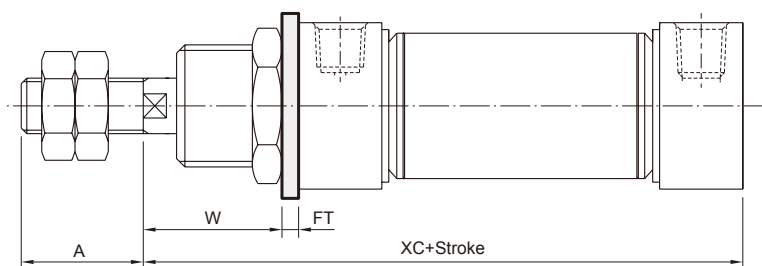
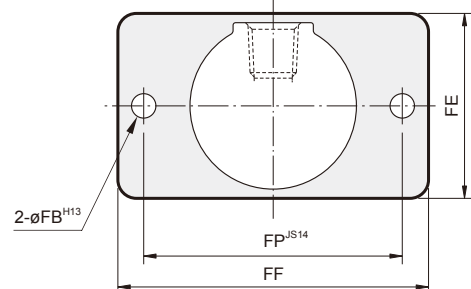

**11**

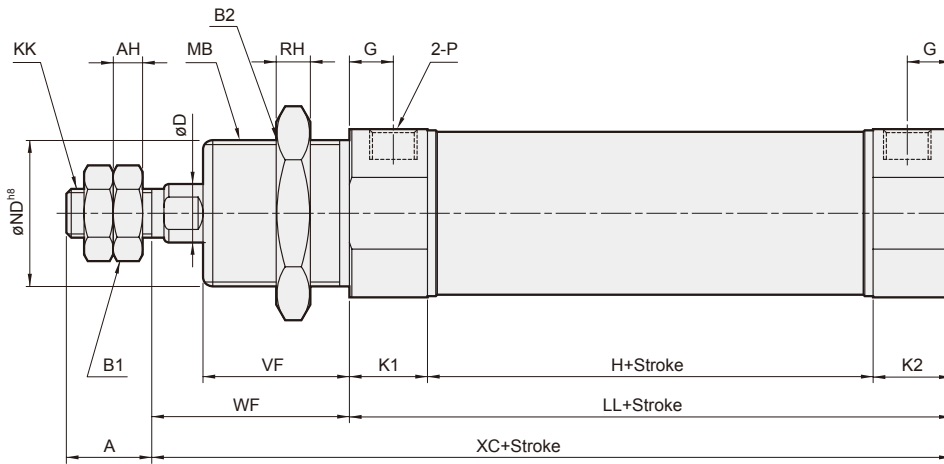

**N**  
Non-pivot type

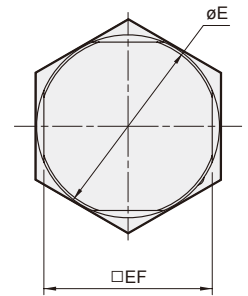

**R H**  
Rod / Head clevis type

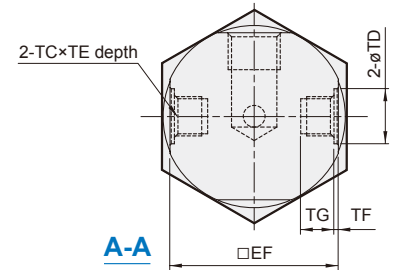
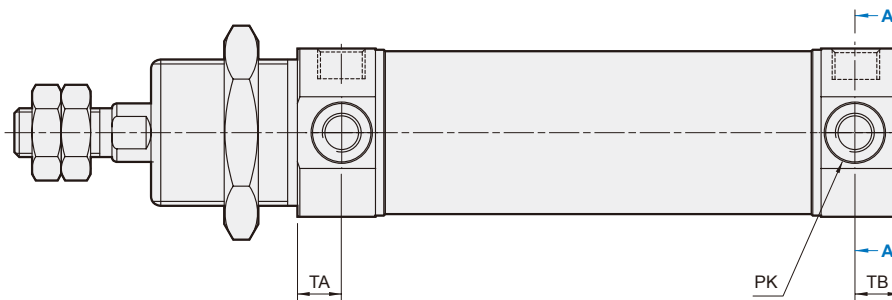

**F**  
Head foot type

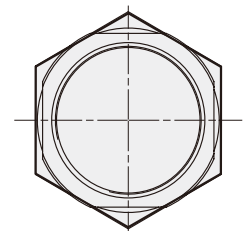
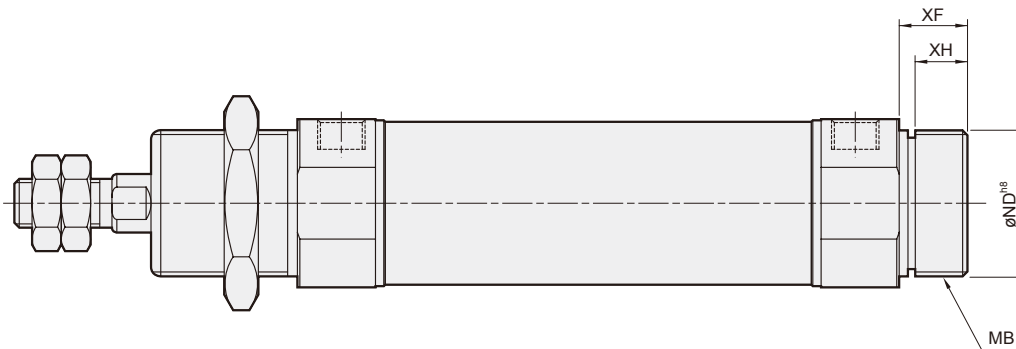

**C**  
Axis port

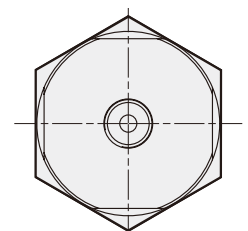
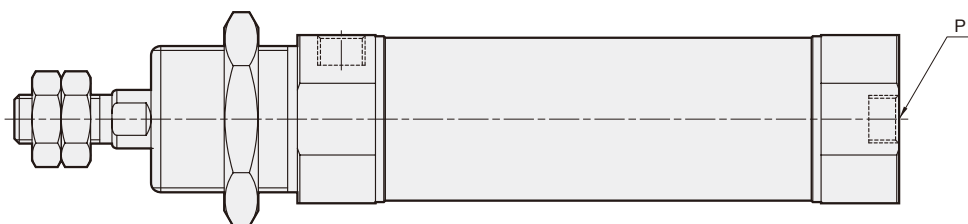

Code Tube I.D.	A	AH	B1	B2	D	E	EF	G	H	KK	K1	K2	LL	MB	ND	P	PK	RH	TA	TB	TC	TD	TE	VF	WF	XC	XF	XH
32	17.5	6	17	38	12	37.5	34.5	9	36	M10×1.5	16	16	68	M30×1.5	30	G1/8	M8×1	7	9	9	M8×1	12	6.5	30	40.5	108.5	14	10.7
40	21	7	19	46	14	46.5	42.5	12	45	M12×1.75	22	22	89	M38×1.5	38	G1/4	M10×1	8	12	12	M10×1	14	8	35	48	137	16	12.2

**SDB**

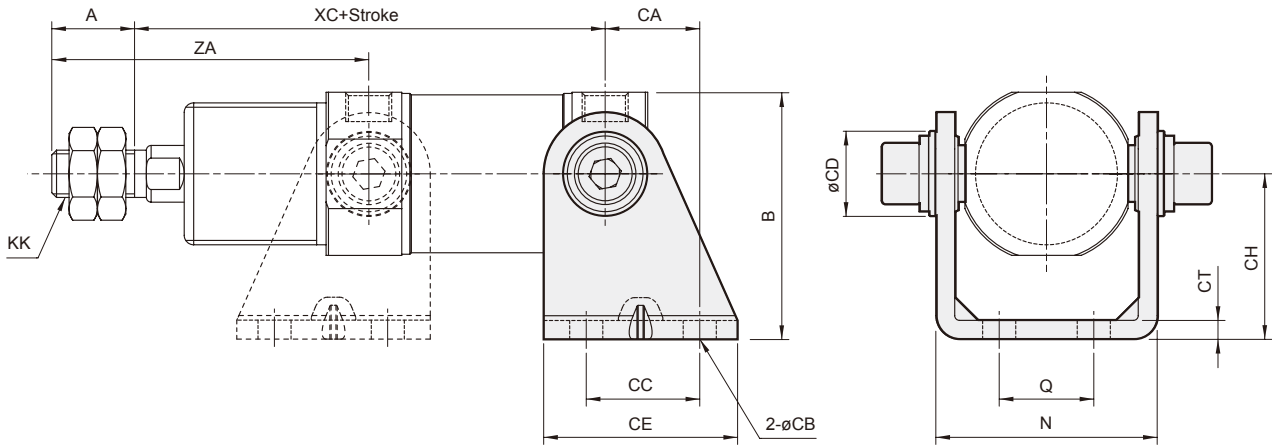

Code Tube I.D.	A	B	CA	CB	CC	CD	CE	CH	CT	KK	N	Q	XC	ZA
32	17.5	52.3	20	7	24	18	41	35	4	M10×1.25	46.8	20	99.5	67
40	21	61.3	27	9	30	22	52	40	4	M12×1.25	58.2	28	125	81

**LB**

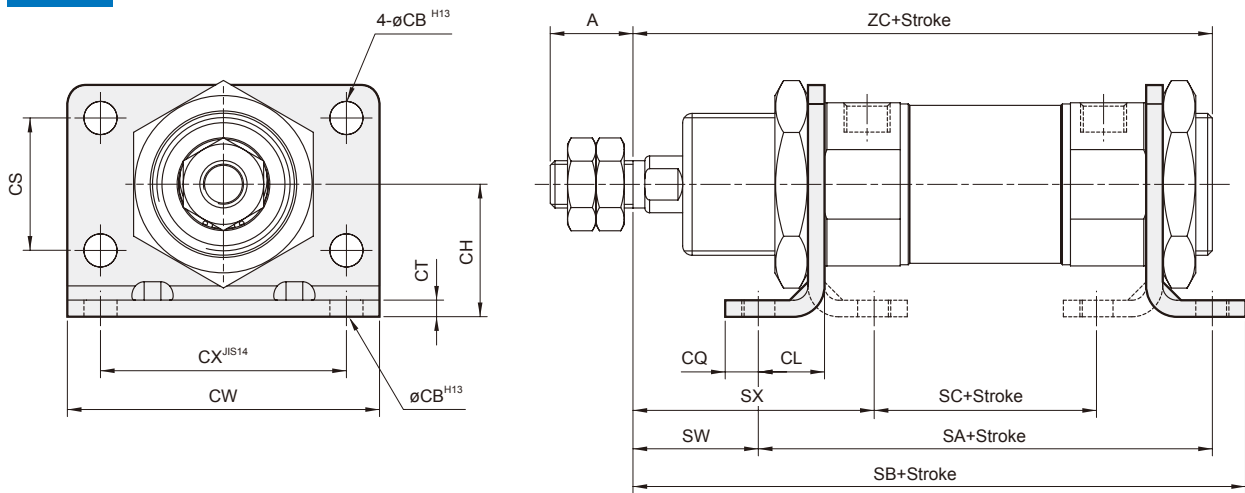

Code Tube I.D.	A	CB	CH	CL	CQ	CT	CW	CX	CS	KK	SA	SB	SC	SW	SX	ZC
32	17.5	7	28	14	7	3.5	66	52	28	M10×1.25	96	129.5	47	26.5	51	122.5
40	21	9	33	20	10	3.5	80	60	30	M12×1.25	129	167	56	28	64.5	153