

COILS	Alternating Current ~50/60Hz Volt							Direct Current Volt			Electrical connection	Connectors
	12	24	48	110	220 230	240	380	12	24	48		
Series 3 Width 22 Code ②	30A	30B	30C	30D	30E	30F	30G	300	301	302	DIN 46244	PG9 code 10348000
Series 4 Width 30 Code ②	40A	40B	40C	40D	40E	40F	40G	400	401	402	DIN 43650 A	PG9 code 10349000

DESCRIPTION
 Class F insulation
 Voltage tolerance
 AC +15% -10%
 DC ± 10%
 Protection class
 IP65 with connector fitted
 IP00 without connector
 Continuous service ED100%

OPTIONS
 Class H insulation
 Cable attached
 Special coil voltage
 Special coil powers

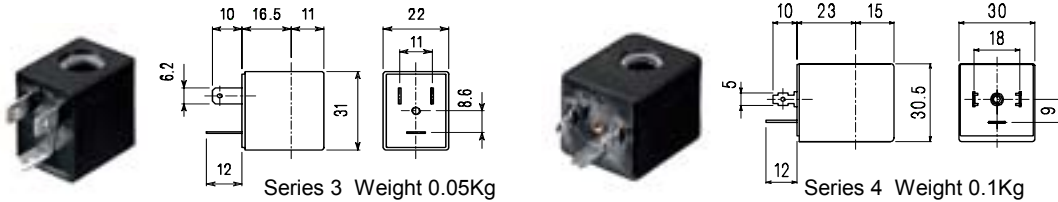

Series 3 Weight 0.05Kg

Series 4 Weight 0.1Kg

SPARE PARTS LIST

1. Coil fixing nut
2. Coil
3. Seal assembly
4. Armature tube with core
5. Diaphragm assembly

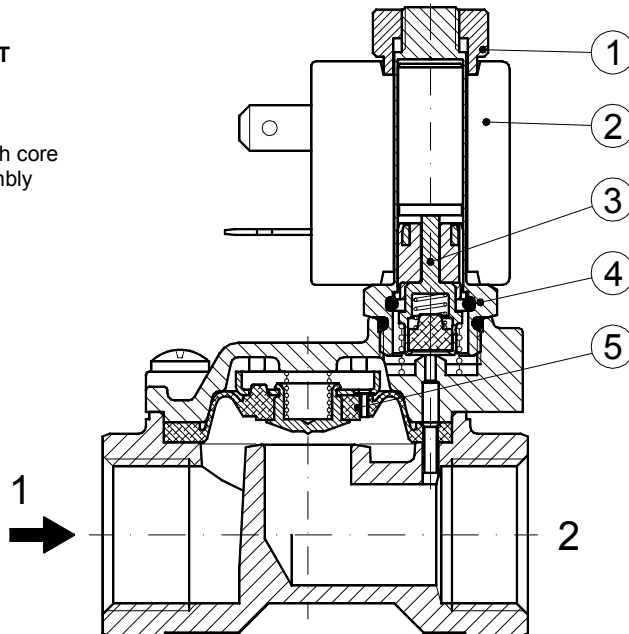

OVERALL DIMENSION

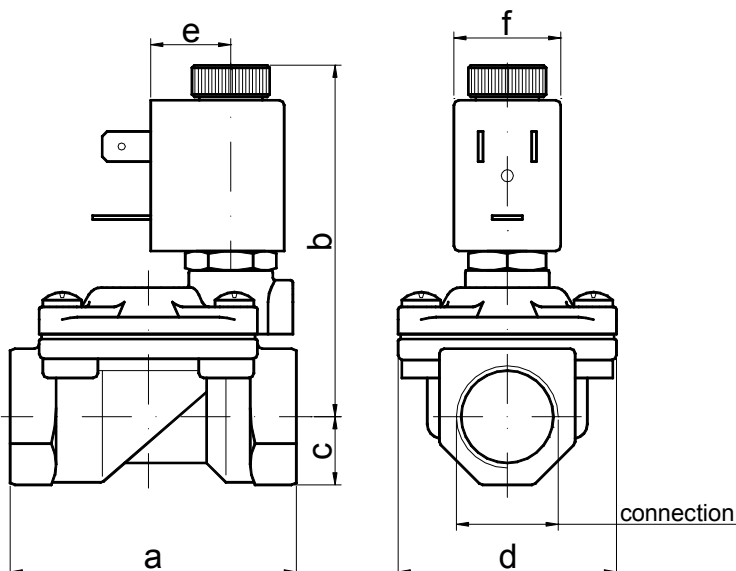

CONNECTION	a	b	c	d	e	f	Weight Kg
G1/4" Ø10	49	64	11	32	16	22	0.25
G3/8" Ø10	49	64	11	32	16	22	0.25
G3/8" Ø12	59	73	14	45	16	22	0.45
G1/2"	59	73	14	45	16	22	0.45
G3/4"	79	75	18	55	16	22	0.66
G1"	96	85	20	72	16	22	1.05
G1 1/4" Ø30	119	96	25	85	16	22	1.80

DESCRIPTION

Solenoid valve 2 way normally open with servo-assisted diaphragm

CONSTRUCTION

Body and cover	Brass
Armature tube	Stainless steel
Plunger and core	Stainless steel
Springs	Stainless steel
Seal	NBR FPM EPDM



FEATURES

- Minimum differential pressure 0.15÷3 bar
- Maximum allowable pressure* : 20 bar
- Maximum fluid viscosity 25cSt (mm²/s)
- Ambient temperature: with class F coil -10°C +55°C
with class H coil -10°C +80°C
- Preferred mounting position with vertical coil above

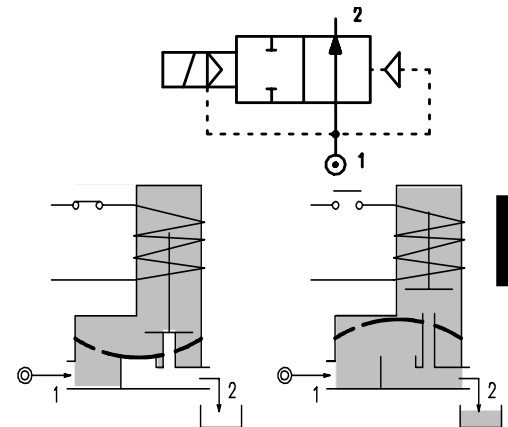

OPTIONS: Electroless nickel plating
Stainless steel armature tube

CODE ① ②	Connection G ISO 228	Orifice mm	KV m ³ /h	Differential pressure bar			Nominal power			Coil		Seal ①	Temp. range °C
				Min	Max		AC Inrush	VA Holding	DC Watt	Series	Width		
					AC	DC							
E207G.....37///.....	1"1/4	37	18	0.15	10	10	20	15	10	2	30	NBR=B	-10 +90
E207H.....37///.....	1"1/2	37	21	0.15	10	10						EPDM=E	<+140
E207I.....50///.....	2"	50	36	0.15	10	10						FPM=V	-10 +130
E207MB75///.....	2"1/2	75	75	0.3	5	5	20	15	10	2	30	NBR=B	-10 +90
E207RB75///.....	3"	75	84	0.3	5	5							
E207MB75/W/.....	2"1/2	75	75	3	15	15	40	30	27	5	36		
E207RB75/W/.....	3"	75	84	3	15	15							

- ① Seal
- ② Coil

Example: E207IB50///201 NBR seal
Coil 24V DC

* REMARK: The maximum allowable pressure PS for steam is 2,5bar (gauge pressure)

COILS	Alternating Current ~50/60Hz Volt							Direct Current Volt			Electrical connection	Connectors
	12	24	48	110	220 230	240	380	12	24	48		
Series 2 Width 30 Code ②	20A	20B	20C	20D	20E	20F	20G	200	201	202	DIN 43650A	PG9 code 10349000
Series 5 Width 36 Code ②	52A	52B	52C	52D	52E	52F	52G	520	521	522	DIN 43650A	PG11 code 10349001

DESCRIPTION
 Insulation class
 Series 2=F Series 5=H
 Voltage tolerance
 AC +15% -10%
 DC ± 10%
 Protection class
 IP65 with connector fitted
 IP00 without connector
 Continuous service ED100%

OPTIONS
 Class H insulation (series 2)
 Cable attached
 Special coil voltages
 Special coil powers

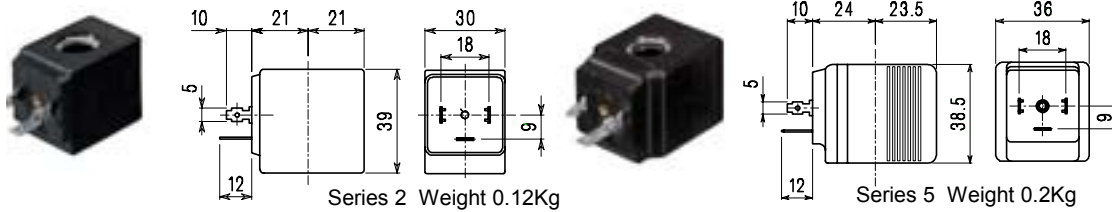

SPARE PARTS LIST

1. Coil fixing nut
2. Coil
3. Plunger
4. Armature tube with core
5. Diaphragm assembly
6. Speed control valve
7. Water hammering reducer
 $\varnothing 0.8\text{-}\varnothing 1\text{-}\varnothing 1.2$

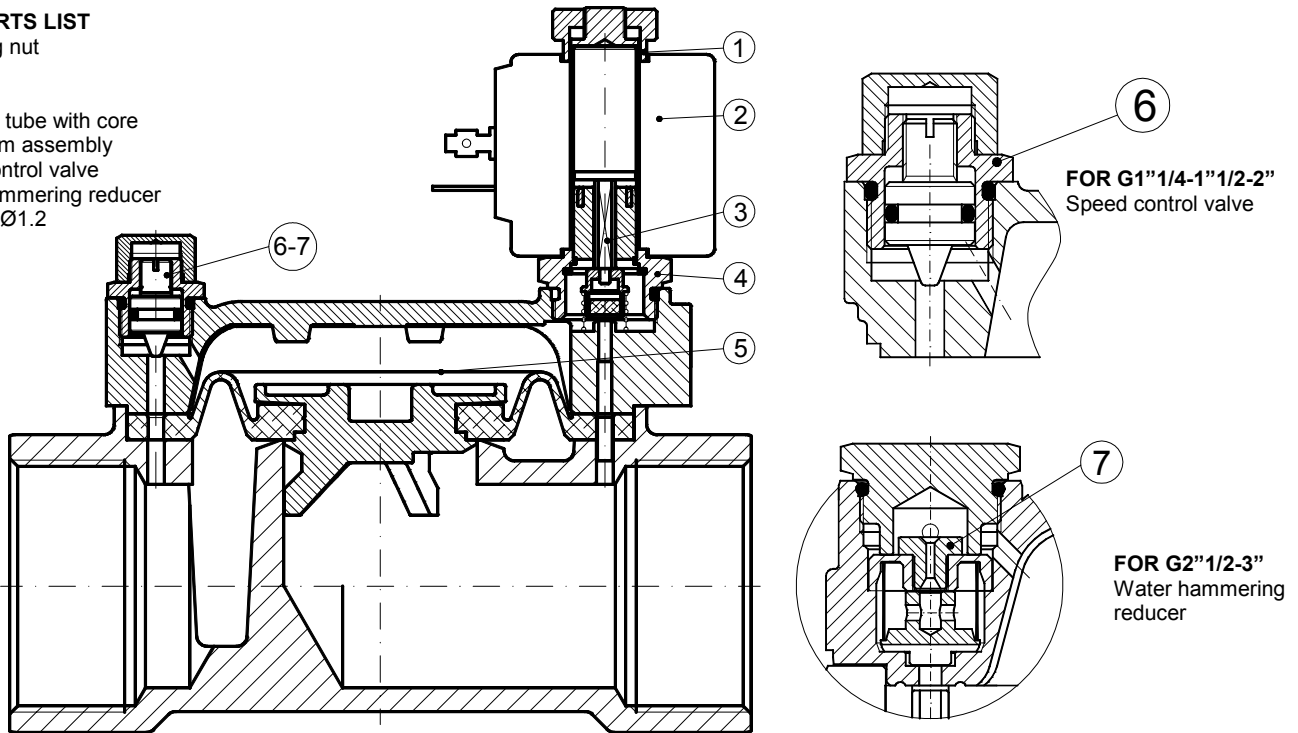

OVERALL DIMENSION

